

1

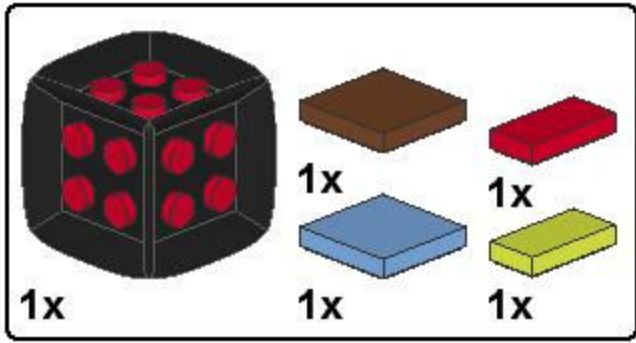

2

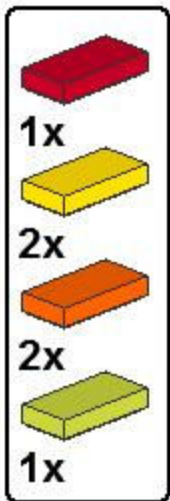

1

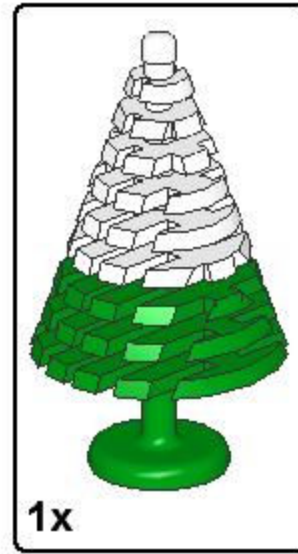

2

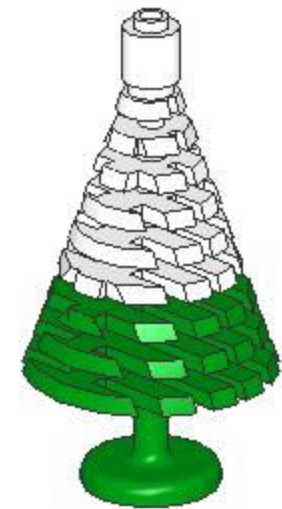
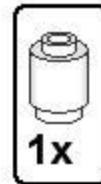

3

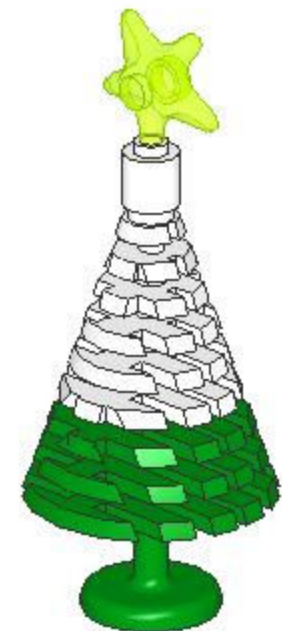
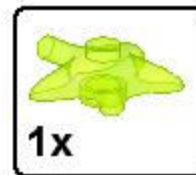

1

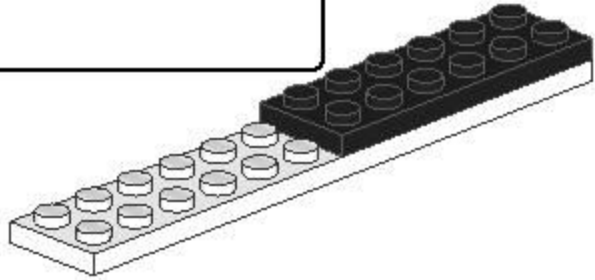
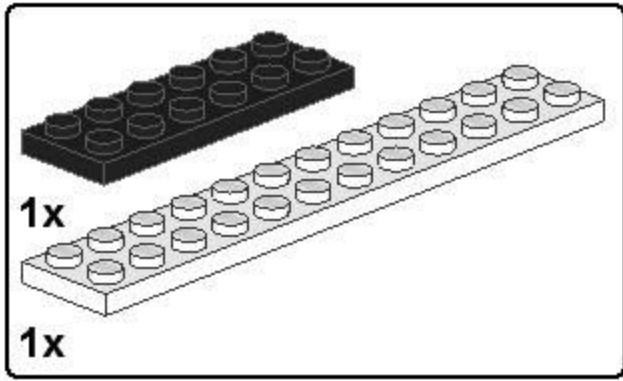

2

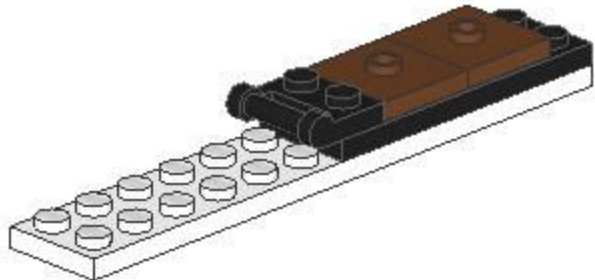
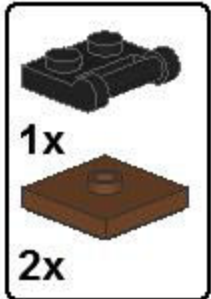

3

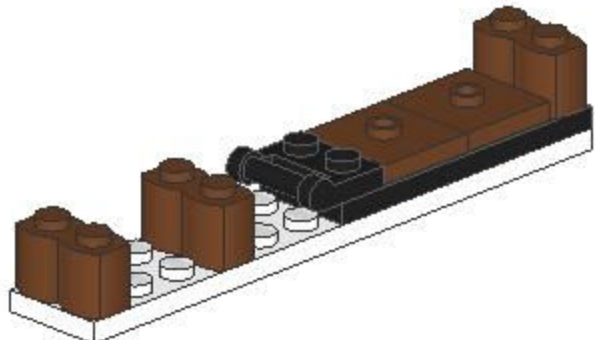
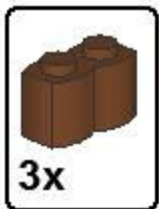

4

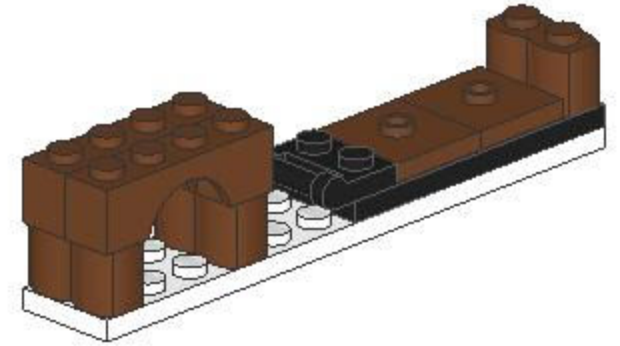
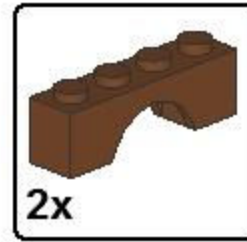

5

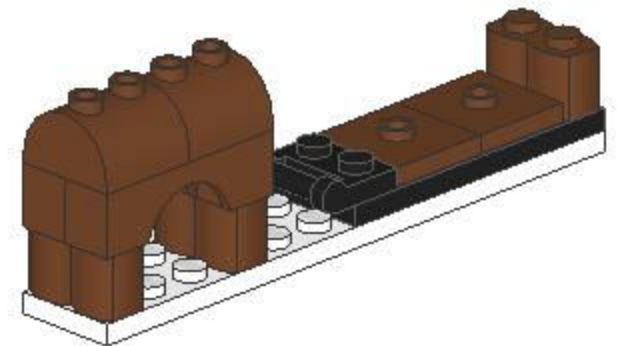
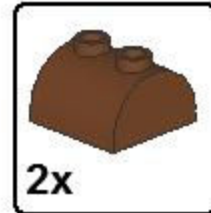

6

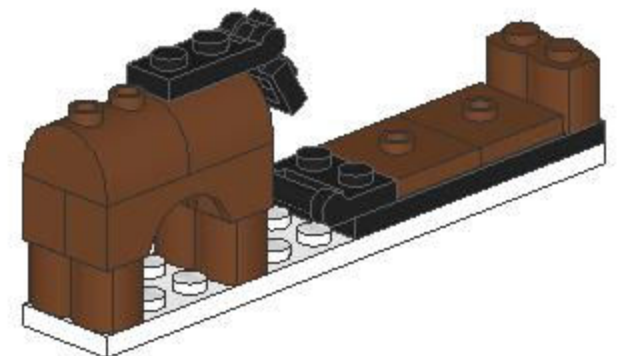
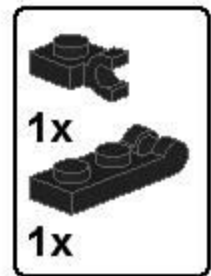

7

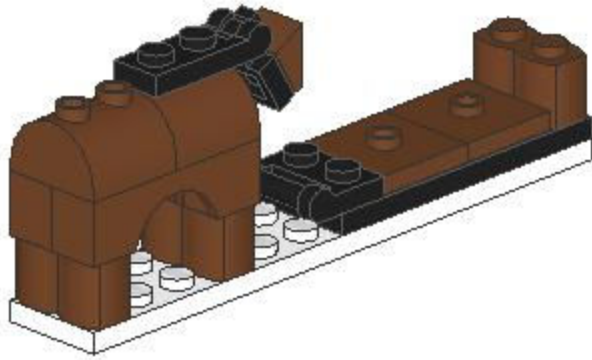
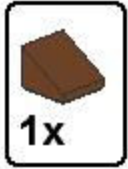

10

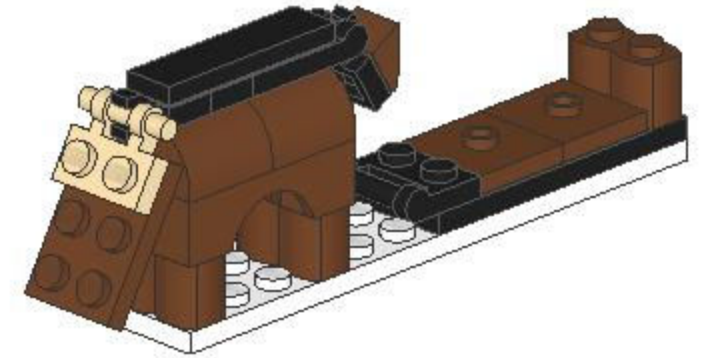
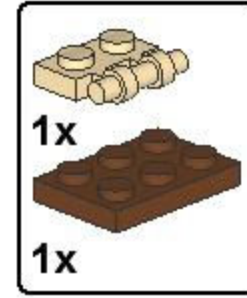

8

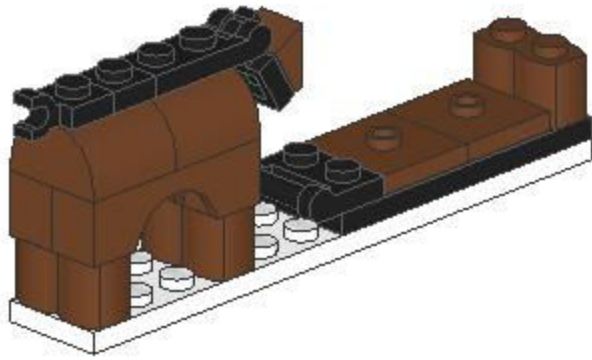
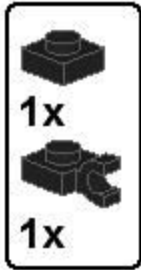

11

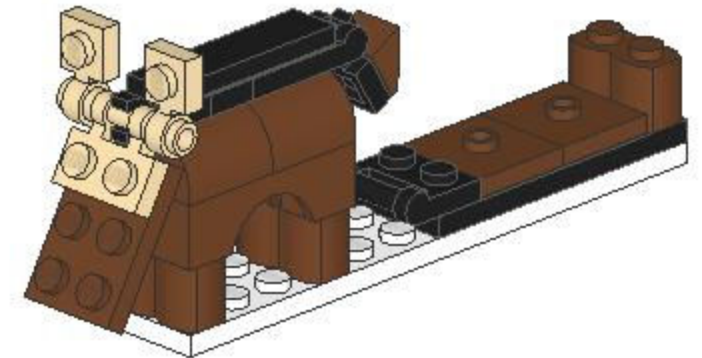
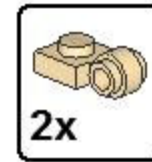

9

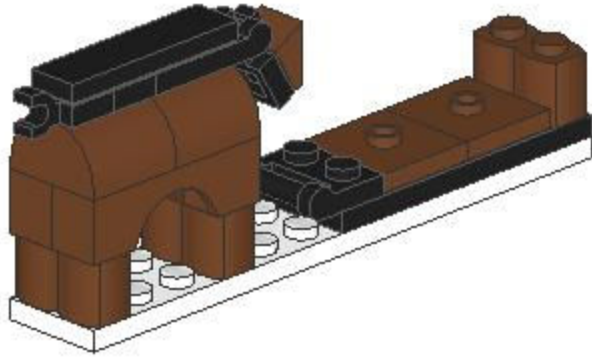
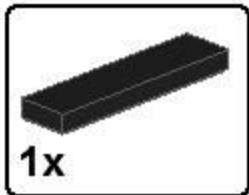

12

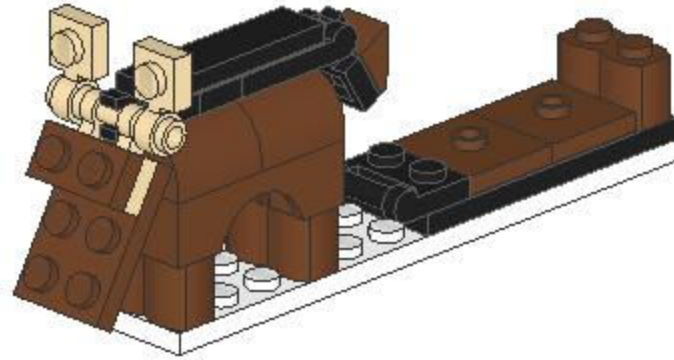
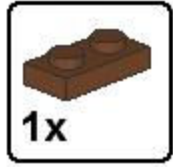

14

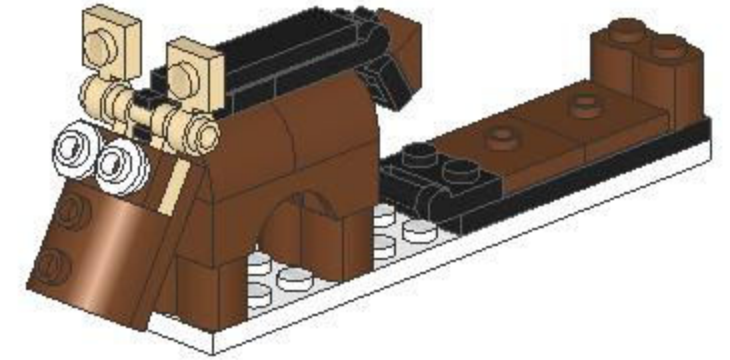
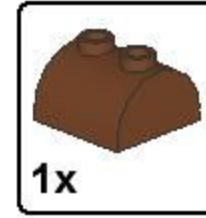

13

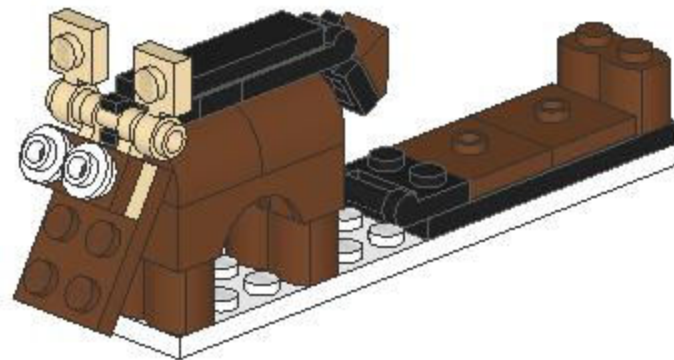
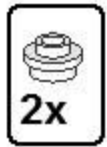

15

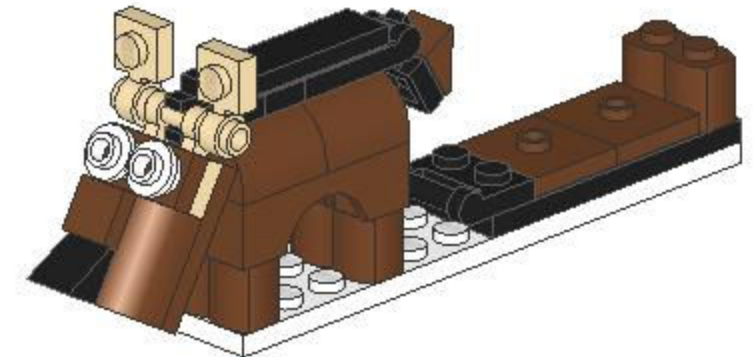

3x

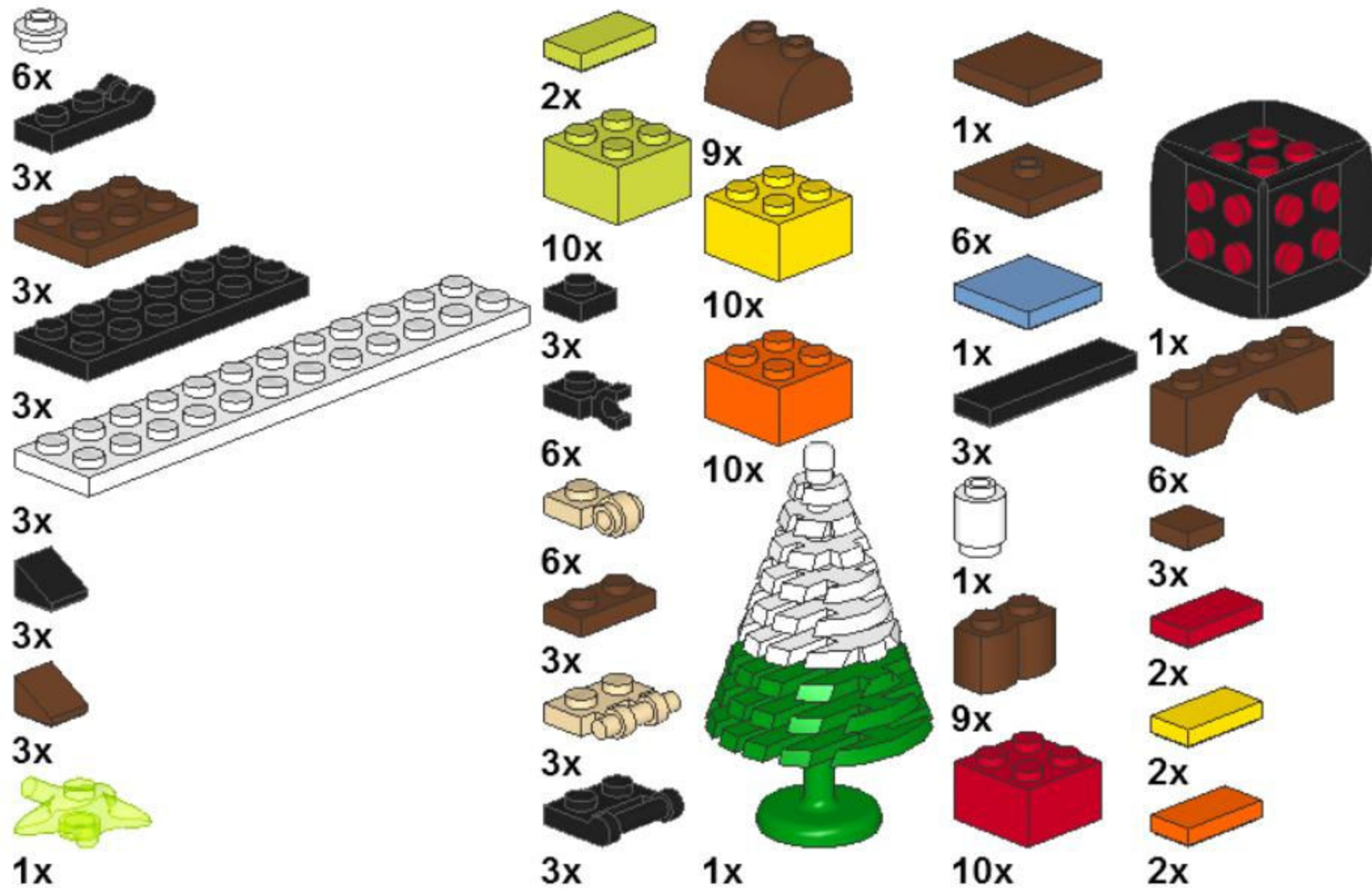

## Instructions for 2010 Happy Holidays

In 2010 this game was given to LEGO® employees around the world as a special treat.

The aim of the game is to collect as large a pile of presents as possible, but you may only count two colours of present when the game ends.

Now here's how you do it:

The youngest player goes first. Play then continues clockwise.

On your turn do the following in order:

If you do not have a reindeer in front of you must take one from in front of any other player.

Roll the LEGO® Dice and carry out the action you rolled.

*Watch out! If you do not have a reindeer in front of you and forget to take one BEFORE you roll you miss your turn!*

The dice has the following sides:

### **4 x Sleigh stack (each showing two colours)**

Do the following in order:

1) Take a gift matching EACH of the colours you rolled from the around the tree and place both onto the sleigh in front of you. If there are no gifts of one colour only take a gift of the other colour. If there are no gifts of either colour, roll again.

2) Choose ONE of the colours you rolled and take ALL the gifts of that colour from the sleigh and place them in front of you.

### **1 x Reindeer reward**

Choose a sleigh and take ALL the gifts from that sleigh and place them in front of you. If you choose a sleigh in front of another player swap the sleigh in front of you with the sleigh you choose.

### **1 x Christmas wish**

Choose a gift colour. Every other player must give you ONE gift of that colour if they have any. Place all the gifts you receive in front of you. If nobody has any gifts roll again.

Stacking your gifts

When you take gifts from a sleigh or receive them from other players make separate stacks of the gifts of each colour you collect and keep them in front of you.

*Remember! If you do not have a reindeer in front of you and forget to take one BEFORE you roll you miss your turn!*

### How to win the game

The game ends when gifts of only ONE colour are left around the tree, or when all the gifts have been taken. Any other gifts left on the sleighs or under the tree are out of the game.

Each player now builds the tallest stack possible using gifts of only TWO colours. Any other gifts collected by each player do not count. The player with the highest combined stack wins the game.